

BASIC ENGINE SPECIFICATIONS

AIR CLEANER – Two stage, dry panel type with rain shield and service indicator. Engine mounted.

BARRING DEVICE – Manual.

BASE – Engine, generator and radiator or heat exchanger are mounted and aligned on a welded steel, wide flange base, designed for solid mounting on an inertia block, with standard through-base holes for lifting.

BREATHER – Closed system.

CONNECTING RODS – Drop forged alloy steel, angle split, serrated joint, oil jet piston pin lubrication.

COOLING SYSTEM – Choice of mounted radiator with pusher fan, core guard and duct adaptor, heat exchanger with shipped loose expansion tank or flanged connections for remote radiator cooling.

CRANKCASE – Alloy cast iron, fully ribbed, integral with cylinder frame.

CRANKSHAFT – Drop forged alloy steel, dynamically balanced and fully counterweighted. Viscous vibration dampener.

CYLINDER HEADS – Individual, interchangeable valve-in-head type with deep section alloy casting. Two hard-faced intake and two hard-faced exhaust valves per cylinder. Replaceable intake and exhaust valve seats. Mechanical valve lifters with pivoted roller followers.

CYLINDERS – Removable wet type liners of centrifugally cast alloy iron.

ENGINE PROTECTION SHUTDOWN CONTACTS – High water temperature, low oil pressure, and overspeed.

EXHAUST – Water-cooled, cast iron exhaust manifolds. Single vertical flexible stainless steel exhaust connection with ANSI 10" 125# outlet flange.

FUEL SYSTEM – Natural gas carburetors, (Deltec on GLD), gas pressure regulator, (GL, one mounted; GLD, one shipped loose) and 24V DC gas solenoid valve (shipped loose). Pressure required: GL models, 25 – 50 psig; GLD models, 8" – 20" W.C.

GENERATOR – Open, drip-proof, direct connected, synchronous, fan cooled, AC revolving field type, 2/3 pitch, single bearing generator with PMG brushless exciter for 300% short circuit sustain (250% for 50 Hz) and motor starting. TIF and Deviation Factor within NEMA MG-1.22. Voltage: 480/277, 3 phase, 12 wire Wye, 60 Hz, and 400/230, 3 phase, 12 wire Wye, 50 Hz. Temperature rise within NEMA 105°C for continuous duty, within NEMA 130°C for standby duty. Voltage regulation is $\pm 0.5\%$. All generators are rated at 0.8 power factor, are mounted on the engine flywheel housing, and have multiple steel disc flexible coupling drive. All continuous power gensets have 10% overload capability.

GOVERNOR – Woodward 4024 Electrically Powered Governor (EPG) control system. Includes mounted actuator and magnetic pickup, and control box (shipped loose). 24V DC operation.

IGNITION – Waukesha Custom Engine Control™ electronic ignition system with coils, cables, hall effect pickup and spark plugs. Non-shielded. 24V DC power required.

INTERCOOLER – Air to water.

INSTRUMENT PANEL – Engine mounted, includes water temperature, oil pressure, intake manifold temperature and intake manifold pressure gauges, and emergency stop pushbutton.

JUNCTION BOXES – Separate AC & DC junction boxes for engine wiring and external connections.

LUBRICATION SYSTEM – Gear type pump, two replaceable element filters and base type oil pan, (43 gal. cap.). Engine mounted shell and tube oil cooler, thermostatic valve for oil temperature control.

PAINT – Oilfield orange.

PISTONS – Aluminum alloy, three ring, with combustion bowl. Oil jet cooled with full floating piston pin. 11:1 compression ratio.

STARTING SYSTEM – 24V DC starting motor. Crank termination switch, (shipped loose).

TURBOCHARGERS – Dry-type with wastegate.

VOLTAGE REGULATOR – Automatic type.

WATER CIRCULATING SYSTEM

Auxiliary Circuit – Gear driven pump for intercooler and oil cooler. Inlet temperature of 130°F (54°C) for all models.

Jacket Water Circuit – 180 - 190°F (82 - 88°C) thermostatic temperature regulation. Gear-driven pump.



VGF36GL/GLD

VGF™ Series Gas Engine Generating System 440 - 645 kW

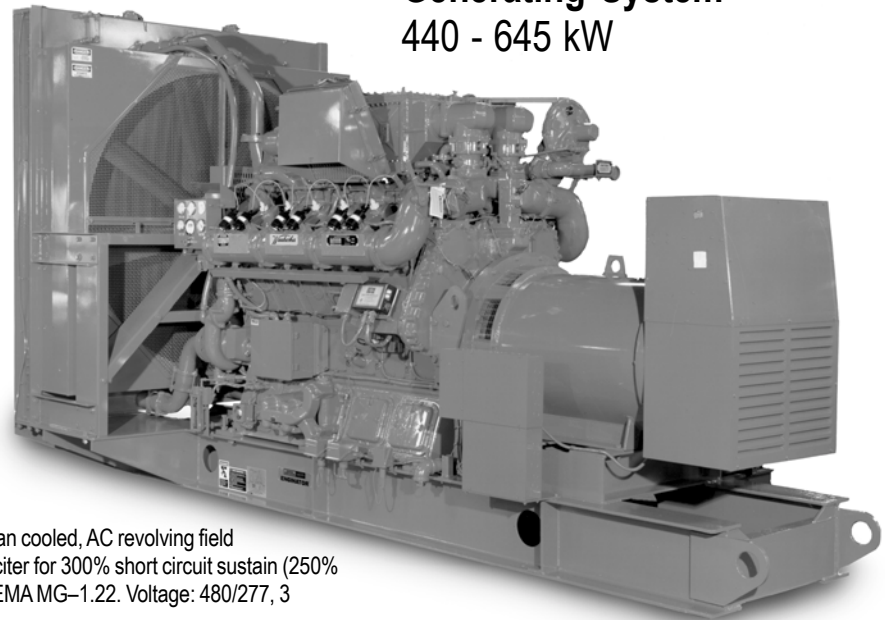

Engine shown with options.

Model VGF36GL/GLD
Turbocharged and Intercooled, Lean Combustion
Gas Fueled Engine

SPECIFICATIONS

Waukesha Engine L36GL/GLD	Jacket Water Capacity
Cylinders V 12	44 gal. (166 L)
Piston Displacement 2193 cu. in. (36 L)	Starting System 24V DC Electric
Bore & Stroke 5.98" x 6.5" (152 x 165 mm)	Fuel LHV 900 Btu/ft ³ (33.5 J/cm ³)
Compression Ratio 11:1	Lube Oil Capacity 43 gal. (163 L)

PERFORMANCE DATA: VGF36GL/GLD GAS ENGINATOR GENERATING SYSTEM

HEAT EXCHANGER COOLING Intercooler Water: 130°F (54°C)	CONTINUOUS POWER*		STANDBY POWER	
	1800 rpm	1500 rpm	1800 rpm	1500 rpm
	560	470	645	535
kW RATING				
Fuel Consumption x 1000 Btu/h (kW)	5685 (1666)	4580 (1342)	6430 (1885)	5215 (1528)
Jacket Water x 1000 Btu/h (kW)	1510 (443)	1261 (370)	1615 (473)	1382 (405)
Intercooler x 1000 Btu/h (kW)	337 (99)	223 (65)	425 (125)	297 (87)
Lube Oil x 1000 Btu/h (kW)	186 (55)	142 (42)	197 (58)	143 (42)
Heat Radiated x 1000 Btu/h (kW)	171 (50)	118 (35)	202 (59)	173 (51)
Exhaust Heat** x 1000 Btu/h (kW)	1570 (460)	1232 (361)	1790 (525)	1395 (409)
Exhaust Flow lb/h (kg/h)	7315 (3318)	5910 (2681)	8320 (3774)	6785 (3078)
Exhaust Temperature °F (°C)	838 (448)	809 (432)	843 (451)	800 (427)
Induction Air Flow scfm (m³/min)	1600 (45)	1295 (37)	1820 (42)	1485 (42)

WATER CONNECTION COOLING Intercooler Water: 130°F (54°C)	CONTINUOUS POWER*		STANDBY POWER	
	1800 rpm	1500 rpm	1800 rpm	1500 rpm
	560	470	645	535
kW RATING				
Fuel Consumption x 1000 Btu/h (kW)	5685 (1666)	4580 (1342)	6430 (1885)	5215 (1528)
Jacket Water x 1000 Btu/h (kW)	1510 (443)	1261 (370)	1615 (473)	1382 (405)
Intercooler x 1000 Btu/h (kW)	337 (99)	223 (65)	425 (125)	297 (87)
Lube Oil x 1000 Btu/h (kW)	186 (55)	142 (42)	197 (58)	143 (42)
Heat Radiated x 1000 Btu/h (kW)	171 (50)	118 (35)	202 (59)	173 (51)
Exhaust Heat** x 1000 Btu/h (kW)	1570 (460)	1232 (361)	1790 (525)	1395 (409)
Exhaust Flow lb/h (kg/h)	7315 (3318)	5910 (2681)	8320 (3774)	6785 (3078)
Exhaust Temperature °F (°C)	838 (448)	809 (432)	843 (451)	800 (427)
Induction Air Flow scfm (m³/min)	1600 (45)	1295 (37)	1820 (52)	1485 (42)

RADIATOR COOLING - MOUNTED Intercooler Water: 130°F (54°C)	CONTINUOUS POWER*		STANDBY POWER	
	1800 rpm	1500 rpm	1800 rpm	1500 rpm
	530	440	620	520
kW RATING				
Fuel Consumption x 1000 Btu/h (kW)	5685 (1666)	4580 (1342)	6430 (1885)	5215 (1528)
Jacket Water x 1000 Btu/h (kW)	1510 (443)	1261 (370)	1615 (473)	1382 (405)
Intercooler x 1000 Btu/h (kW)	337 (99)	223 (65)	425 (125)	297 (87)
Lube Oil x 1000 Btu/h (kW)	186 (55)	142 (42)	197 (58)	143 (42)
Heat Radiated x 1000 Btu/h (kW)	171 (50)	118 (35)	202 (59)	173 (51)
Exhaust Heat** x 1000 Btu/h (kW)	1570 (460)	1232 (361)	1790 (525)	1395 (409)
Exhaust Flow lb/h (kg/h)	7315 (3318)	5910 (2681)	8320 (3774)	6785 (3078)
Exhaust Temperature °F (°C)	838 (448)	809 (432)	843 (451)	800 (427)
Induction Air Flow scfm (m³/min)	1600 (45)	1295 (37)	1820 (52)	1485 (42)
Radiator Air Flow scfm (m³/min)	75000 (2124)	63000 (1784)	75000 (2124)	63000 (1784)

Typical heat balance data is shown. Consult factory for guaranteed data.

***Continuous Power Rating:** The highest electrical power output of the Enginator available for an unlimited number of hours per year, less maintenance. It is permissible to operate the Enginator with up to 10% overload for two hours in each 24 hour period.

Standby Power Rating: This rating applies to those systems used as a secondary source of electrical power. This rating is the electrical power output of the Enginator (no overload) 24 hours a day, for the duration of the primary power source outage.

Rating Standard: The Waukesha Enginator power rating descriptions are in accordance to ISO 8528, DIN6271 and BS5514. It is also valid for ISO 3046/1-1986 with an engine mechanical efficiency of 90% and auxiliary water temperature T_{cr} (clause 10.0) is limited to ± 10° F (5° C).

**Heat rejection based on cooling exhaust gas to 85° F (29° C).

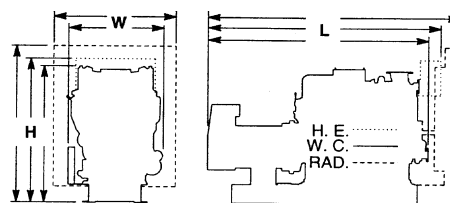

Cooling Equipment	L in (mm)	W in (mm)	H in (mm)	Avg. Wt. lb (kg)
Heat Exchanger	157 (3990)	57 (1450)	96 (2440)	17000 (7720)
Water Cooler	137 (3480)	57 (1450)	89 (2260)	16000 (7260)
Radiator	188 (4780)	105 (2670)	124 (3150)	20500 (9300)



Waukesha

WAUKESHA POWER SYSTEMS

WAUKESHA ENGINE
DRESSER, INC.
1000 West St. Paul Avenue
Waukesha, WI 53188-4999
Phone: (262) 547-3311 Fax: (262) 549-2795
waukeshaengine.dresser.com

Bulletin 8071 0501

WAUKESHA ENGINE

DRESSER INDUSTRIAL PRODUCTS, B.V.
Farmsumerweg 43, Postbus 330
9900 AH Appingedam, The Netherlands
Phone: (31) 596-652222 Fax: (31) 596-628111

Consult your local Waukesha Distributor for system application assistance. The manufacturer reserves the right to change or modify without notice, the design or equipment specifications as herein set forth without incurring any obligation either with respect to equipment previously sold or in the process of construction except where otherwise specifically guaranteed by the manufacturer.