

Intermediate  
Series

**F817**

BULLETIN 6041A

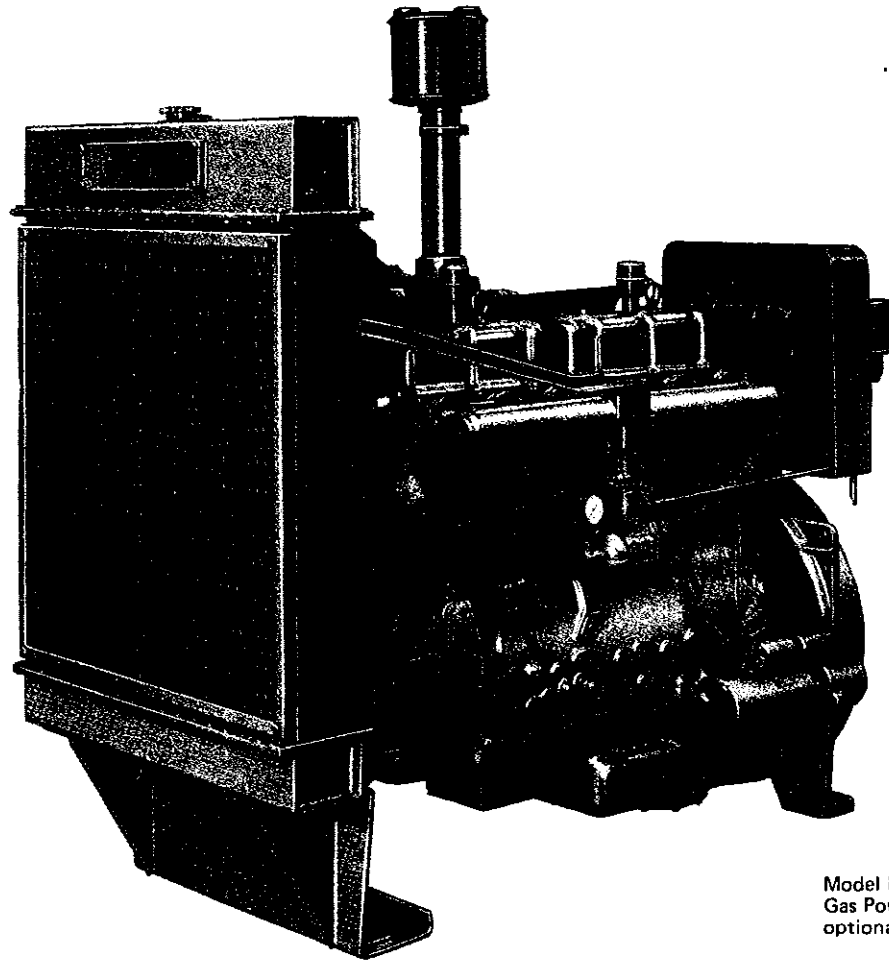

Model F817GU  
Gas Power Unit with  
optional accessories.

**PRINCIPAL ENGINE DATA**

Maximum BHP at Indicated RPM . . . . .  
 Maximum Torque at Indicated RPM (Lb. Ft.) . . . . .  
 Bore and Stroke . . . . .  
  
 Number of Cylinders . . . . .  
 Displacement . . . . .  
 Number of Main Bearings . . . . .  
 Lube Oil System, Capacity  
   Engine, not including lines and filters . . . . .  
   Filter, mounted . . . . .  
 Jacket Water System, Capacity  
   Engine without radiator . . . . .  
   Engine with radiator-cooling . . . . .  
 Weight  
   Unit without radiator (approximate) . . . . .  
   Unit with radiator, sheet steel housing  
     and side door (approximate) . . . . .

**MODEL F817GU**

190 @ 2000  
 553 @ 800  
 5.375 in. x 6.0 in.  
 (137 mm x 152 mm)  
 6  
 817 cu. in (13.3 liters)  
 7  
  
 4.5 gal. (17 liters)  
 1 gal. (3.8 liters)  
  
 9.75 gal. (36.9 liters)  
 18 gal. (68 liters)  
  
 2750 lb. (1250 kg)  
 3400 lb. (1545 kg)

# SPECIFICATIONS

## STANDARD EQUIPMENT

### MODEL F817GU POWER UNIT

Engine — Inline, 6 cylinder, overhead valve, 4-cycle.

Air Cleaner — Oil bath type.

Bearings — Heavy duty, replaceable precision type.

Carburetor — Gas, 2 in. (51 mm) updraft with gas pressure test gauge.

Connecting Rods — Drop forged steel, rifle drilled.

Crankshaft — Forged steel, seven main bearings, hardened journals, dynamically balanced.

Crankshaft Pulley — 8.31 in. (211 mm) O.D. Five .5 in., two .38 in. grooves.

Cylinders — Removable wet cylinder liners.

Cylinder Heads — Interchangeable front or rear, valve-in-head type. Stillite faced exhaust valves. Stellite exhaust valve seat inserts.

Engine Rotation — Counterclockwise when facing flywheel.

Flywheel — With ring gear. Machined for SAE 14 in. (356 mm) over-center clutch.

Flywheel Housing — Foot type. SAE No. 0.

Front Support — Unit.

Governor — Waukesha built-in centrifugal type.

Ignition — Semi-low tension magneto and cables. One spark plug per cylinder.

Instrument Panel — Engine mounted, including ignition switch, oil pressure gauge, water temperature gauge.

Lifting Eyes

Lubrication — Full pressure gear type pump, bypass type oil filter.

Manifolds — Exhaust, hot, center up with threaded flange connections for 3 in. pipe. Intake, updraft.

Muffler — And exhaust pipe.

Oil Pan — Rear sump.

Paint — Oil field orange.

Pistons — Aluminum with floating pin, Chrome plated top ring. Compression ratio 9:1.

Throttle Control — Friction type.

Water Circulating System — Belt driven water circulating pump. 170°F (77°C) thermostats, by-pass type.

## OPTIONAL ACCESSORIES

(Available as original equipment when specified)

Air Cleaners — Dry type. Oil bath with precleaner.

Auxiliary Drives and Equipment — Air compressor, hydraulic pump.

Controls — Vacuum compensating and hydraulic governors.

Cooling — Radiator, heat exchanger.

Electrical — 12 volt 32 amp. alternator.

Enclosure — Protective sheet steel hood, rear panel, side doors. Instruments mounted in rear panel.

Engine Modification — For speed over 1600 rpm.

Exhaust Manifold — Water-cooled, rear outlet.

Filter, Oil — Full flow, mounted.

Fuel System — Sewage gas carburetor. LPG (HD-5 Propane) equipment. Gas pressure regulator.

Ignition System — Distributor. Low tension magneto, non-shielded and shielded solid state magneto.

Instruments — Oil temperature and vacuum gauges, ammeter, tachometer, hour meter.

Oil Cooler

Power Take-Off — Clutch PTO. Stub shaft for direct drive. Torque converter. Flexible coupling.

Safety Switches — Low oil pressure and high water temperature cutoff. Manual reset.

Starting — 12 volt electric, air.

## OUTLINE DRAWING FOR CLOSED POWER UNIT

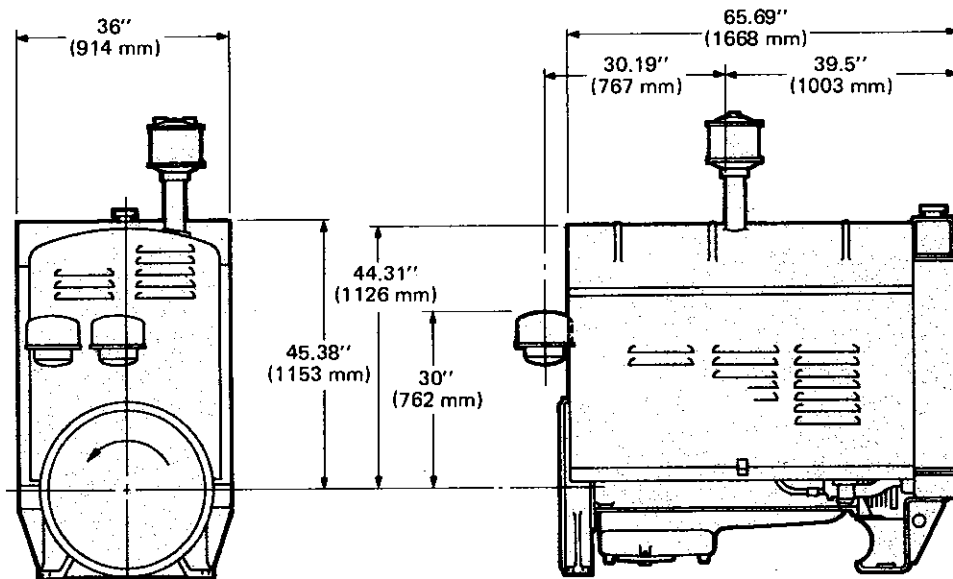

Components and accessory locations and dimensions may vary with service and installation requirements. Dimensions not guaranteed. Detailed print available for layout work. Reference installation drawing L-8018-35.

# POWER RATINGS

M = MAXIMUM

I = INTERMITTENT

C = CONTINUOUS

MODEL	COMPRESSION RATIO	MAX. TORQUE @ RPM (LB. FT.)	BRAKE HORSEPOWER AT SPEEDS INDICATED										CURVE NO.														
			800			1000			1200			1400			1500			1600			1800			2000			
			M	I	C	M	I	C	M	I	C	M		I	C	M	I	C	M	I	C	M	I	C	M	I	C
<b>NATURAL GAS WITHOUT ACCESSORIES</b>																											
F817G	9:1	581-1000	88	84	75	111	105	94	132	126	113	153	145	130	164	156	139	174	165	148	193	183	-	210	199	-	C176A
F817G	7.2:1	559-1200	85	80	72	106	101	90	128	121	109	146	139	124	153	145	130	162	154	138	176	168	-	189	180	-	C174A
F817G	9.1*	526-800	80	76	68	100	95	85	120	114	102	140	133	119	-	-	-	-	-	-	-	-	-	-	-	-	C182A
F817G	7.2:1*	506-1000	77	73	65	96	92	82	115	109	98	132	126	113	-	-	-	-	-	-	-	-	-	-	-	-	C180A
<b>NATURAL GAS WITH ACCESSORIES</b>																											
F817GU	9:1	553-800	84	80	72	105	100	89	124	119	106	142	135	121	152	144	129	161	153	137	177	168	-	190	180	-	C177A
F817GU	7.2:1	529-800	81	77	69	100	95	85	120	114	102	135	128	115	141	134	120	149	142	127	160	152	-	169	161	-	C175A
F817GU	9.1*	500-800	76	72	65	94	89	80	112	106	95	129	122	109	-	-	-	-	-	-	-	-	-	-	-	-	C183A
F817GU	7.2:1*	476-800	73	69	62	90	86	77	107	102	91	121	115	103	-	-	-	-	-	-	-	-	-	-	-	-	C181A
<b>HD-5 PROPANE WITHOUT ACCESSORIES</b>																											
F817G	9:1	581-1000	88	84	75	111	105	94	132	126	113	153	145	130	164	156	139	174	165	148	193	183	-	210	199	-	C178B
<b>HD-5 PROPANE WITH ACCESSORIES</b>																											
F817GU	9:1	553-800	84	80	72	105	100	89	124	119	106	142	135	121	152	144	129	161	153	137	177	168	-	190	180	-	C179A

Ratings are corrected to sea level barometric pressure of 29.92" (760 mm) Hg. and standard temperature of 60° F (16° C).  
Performance Curve Supplied on Request.  
Ratings are based on availability of 1000 BTU LHV gas. For natural gas having less than 1000 BTU LHV, see chart S3955A for percentage loss of horsepower. For sewage gas ratings consult Waukesha Engine Division.

\* Slow Speed Camshaft.

## RATING STANDARDS

### MAXIMUM RATING

- The maximum power capability of a naturally aspirated engine, which is inherently limited in power output by design, temperature, and barometric pressure.
- This rating can be demonstrated within 5% at the factory under standard conditions of atmospheric pressure and temperature. Engine should not be applied at this rating.

### INTERMITTENT RATING

- The highest load and speed which can be applied under specific conditions of varying load and/or speed.

### CONTINUOUS RATING

- The load and speed which can be applied without interruption except for normal maintenance.

**SPECIAL RATINGS:** All published ratings of the Waukesha Engine Division are a general guide for a broad range of applications. Other ratings based on specific load applications and economic requirements are available upon receipt at the factory of detailed information.

## DEDUCTIONS FOR ALTITUDE AND TEMPERATURE\*

Type of Engine	RATING		
	Maximum	Intermittent	Continuous
Naturally Aspirated	3% for each 1000' above sea level	3% for each 1000' altitude	3% for each 2000' altitude
	1% for each 10° over 60° F	1% for each 10° over 80° F	1% for each 10° over 100° F

\* No greater correction factor than 1.000 can be used in determining the specific rating.

The manufacturer reserves the right to change or modify without notice, the design, equipment specifications or ratings as herein set forth without incurring any obligation either with respect to engines previously sold or in the process of construction except where otherwise specifically guaranteed by the manufacturer.

## OUTLINE DRAWING FOR OPEN POWER UNIT

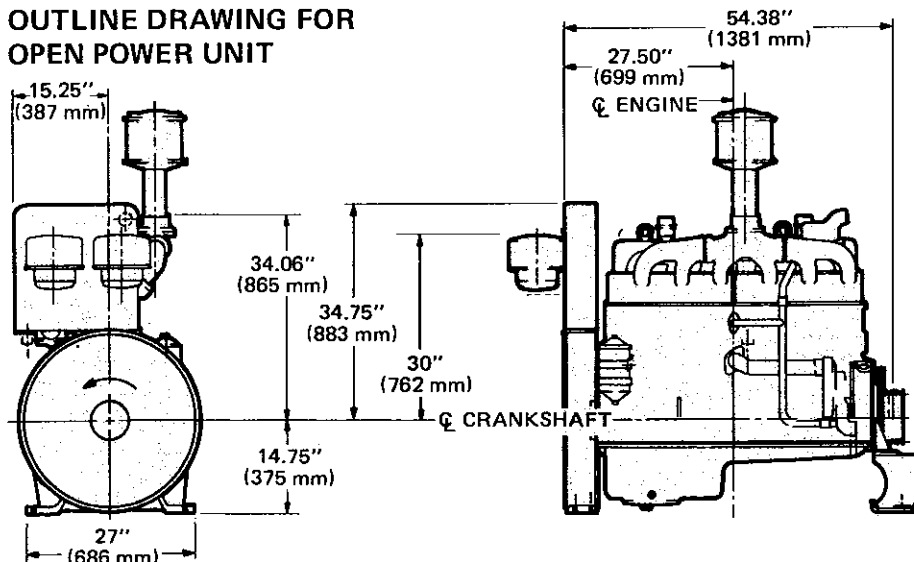

Components and accessory locations and dimensions may vary with service and installation requirements. Dimensions not guaranteed. Detailed print available for layout work. Reference installation drawing L-8018-43.

# PERFORMANCE CURVES

All ratings corrected to 29.92 in. (760 mm) Hg. and 60° F (16° C).

- Curve A:** Maximum Rating of Engine with Accessories
- Curve B:** Intermittent Rating of Engine with Accessories
- Curve C:** Continuous Rating of Engine with Accessories

## Model F817GU Power Unit – Naturally Aspirated 9:1 Compression Ratio – 1000 BTU Dry Natural Gas

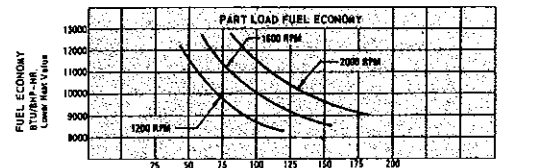
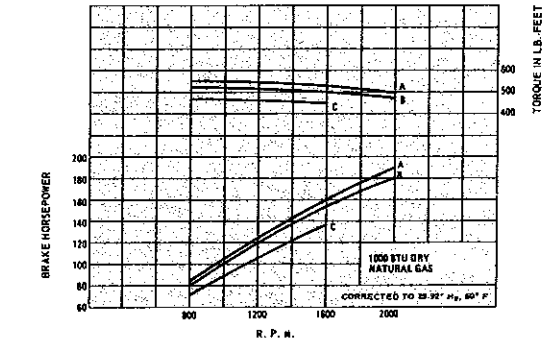

**C177A**

## Model F817GU Power Unit – Naturally Aspirated 7.2:1 Compression Ratio – 1000 BTU Natural Gas

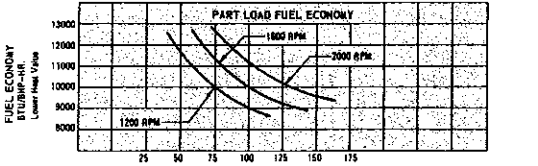
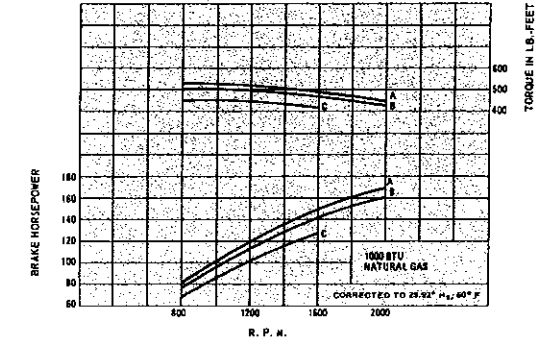

**C175A**

## Model F817GU Power Unit – Naturally Aspirated 9:1 Compression Ratio – 1000 BTU Dry Natural Gas (Slow Speed Camshaft)

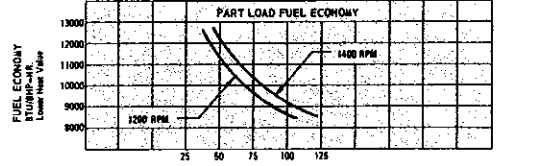
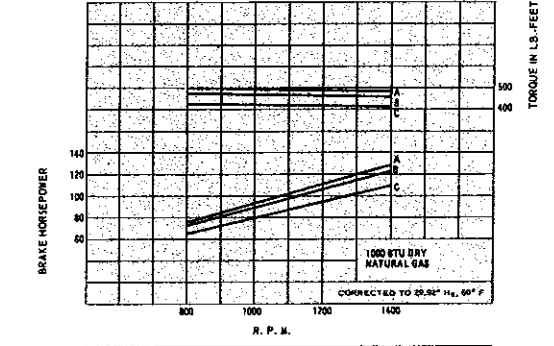

**C183A**

## Model F817GU Power Unit – Naturally Aspirated 7.2:1 Compression Ratio – 1000 BTU Natural Gas (Slow Speed Camshaft)

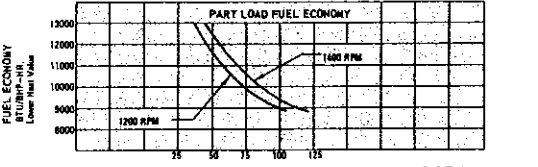
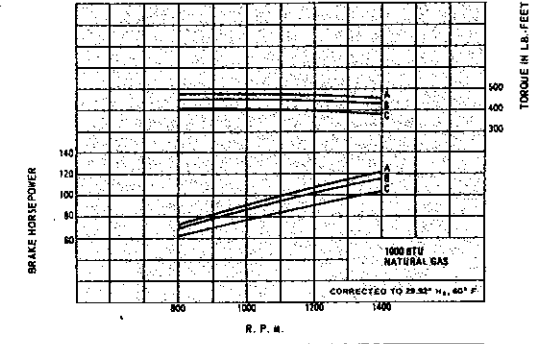

**C181A**

## Model F817GU Power Unit – Naturally Aspirated 9:1 Compression Ratio – HD-5 Propane

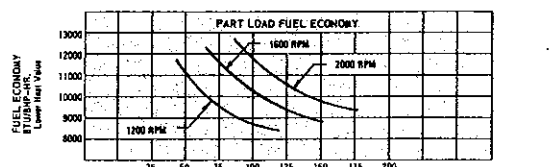
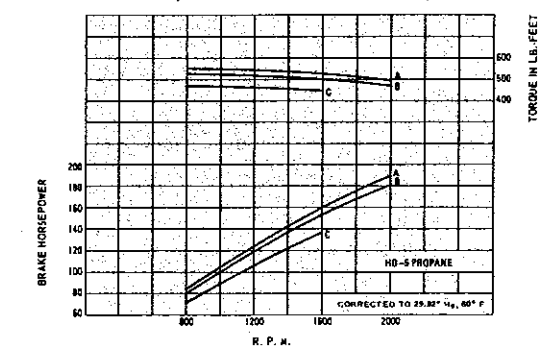

**C179A**

Waukesha

WAUKESHA ENGINE DIVISION  
DRESSER INDUSTRIES INC.  
WAUKESHA, WISCONSIN 53187

Your Distributor: