

Your Reliable Guide for Power Solutions

When Should the Neutral be Switched?

Information Sheet # 05

An issue frequently considered by system designers is when to switch the neutral of a transfer switch used on a standby generator system. This info sheet examines the issue and offers some recommendations.

When the neutral of a system is grounded, a 2-pole (single phase) and 3-pole (three phase) transfer switch is selected, and the neutral is a solid link with only the phase contacts carrying the load being switched. If it is determined, mainly for personnel and equipment safety, the neutral has to be switched, then the transfer switch selected would be 3-pole (single phase) and 4-pole (three phase), with the additional pole switching the neutral.

Before considering the reasons for switching the neutral, we have to consider regulations of NEC 230-95 and NFPA 70-1996 that lay out procedures for Ground Fault Protection (GFP). Entities such as NEC and NFPA that specify safety standards are concerned that grounding the neutral alone does not provide full protection from stray electrical currents and other faults occurring in current carrying conductors. NEC makes the following distinctions between system and equipment grounding:

System Ground: A system ground is a connection to ground from the current carrying conductors of a circuit or interior wiring system.

Equipment Ground: Where the equipment body not carrying current has metal parts, such as the generator or metal conduit is grounded.

System Neutral Ground: This is when the neutral point of a transformer, electric motor, or system is grounded. The neutral point is where the same potential is found, if any of the free ends of the system are connected to the appropriate main terminal or system line.

NEC recognizes that while the utility supply grounds the neutral of the power transformer supplying the user, personnel and equipment safety can be at risk from transient voltages from line to ground during switching and ungrounded neutral faults on connected equipment. Therefore, the NEC requires that GFP devices must be used for all solidly-grounded wye services. GFP devices are designed to detect phase to ground faults. To avoid unintended paths that can go around the GFP device, it is important to avoid several neutral grounding points and have the service neutral grounded at the main distribution board.

The following summarizes when to select switched neutral over solid neutral:

1) When to select a Solid Neutral: *(Graphic One shows a diagram of a system with solid neutral)*

When the designer can incorporate the generator system into the rest of the system, the generator set neutral is not grounded, and a transfer switch with solid neutral can be used. When the neutral is common to the normal and standby systems, in the event of a fault, there could be some division of current that would occur in the event of a ground fault. In this case, the 3-pole transfer switch must have contacts designed to withstand fault currents for the period of time taken and required for the GFP device to trip.

To fulfill our commitment to be the leading supplier in the power generation industry, the Kraft Power Corporation team ensures they are always up-to-date with the current power industry standards as well as industry trends. As a service, our **Information Sheets** are circulated on a regular basis to existing and potential power customers to maintain their awareness of changes and developments in standards, codes and technology within the power industry.

2) When to Switch the Neutral: (Graphic Two shows a diagram of a system with a switched neutral)

When the generator system is required to be separately grounded at site, a transfer switch with a switchable neutral should be selected. With a switched neutral, the generator set can be wired as a separately derived system to the load and normal power supply. In this configuration, the neutral is not solidly connected through the transfer switch, but switched. Also, the neutral is designed to be switched simultaneously with the switching of the load carrying phases. By utilizing this system, the designer/user will ensure GFP operation as intended by NEC codes.

In the switched neutral mode, the generator is a separately derived system to the rest of the electrical system with its neutral grounded at the housing. The neutral return path is left open for ground return currents by the transfer switch contacts. In addition, nuisance tripping caused by unbalanced loads is avoided. The generator set is totally separate to the utility supply and a safe alternative to a solid neutral connection.

Another example where a switched neutral connection is preferable is when there is more than one separately derived electrical system being backed up by a common power source. An example of this would be a building being fed by two different utility sources. For this type of installation, each utility service would have its own separately derived neutral ground. To properly back-up portions of each utility service, the installation would require two transfer switches. If the transfer switches had solid neutrals, each system would have two grounding paths. To avoid this scenario, the designer would select a transfer switch with a switchable neutral pole to maintain the single path to ground system.

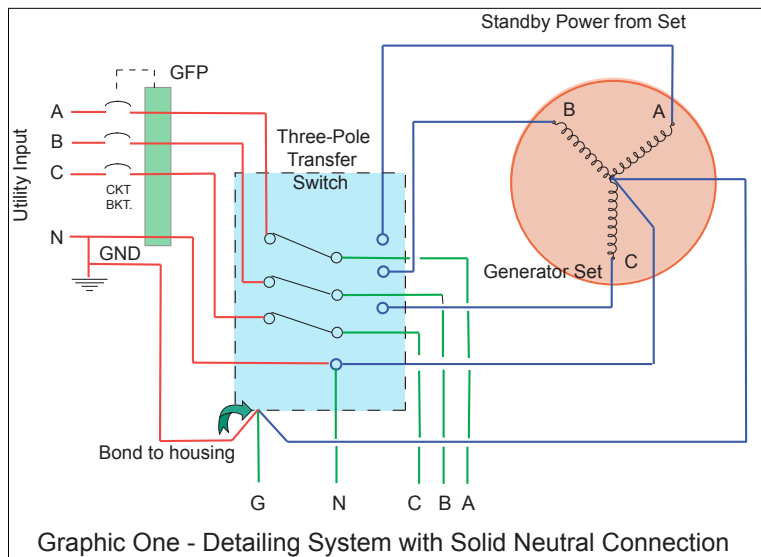

Graphic One - Detailing System with Solid Neutral Connection

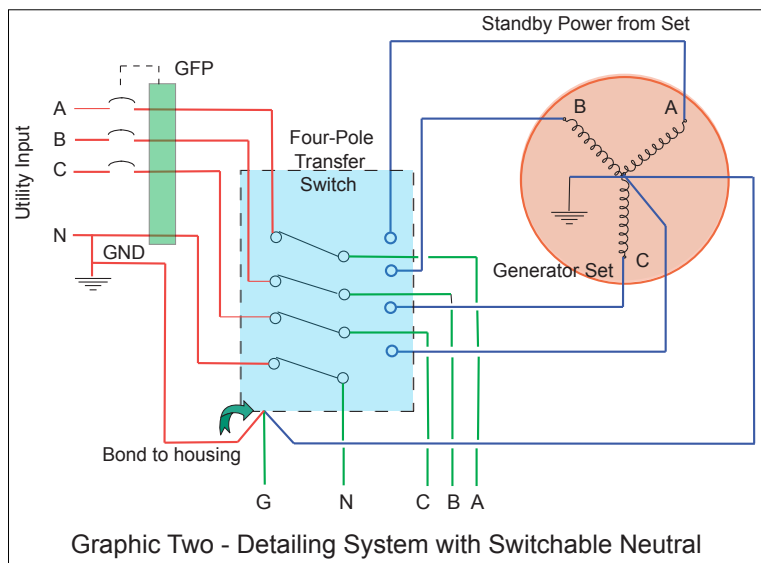

Graphic Two - Detailing System with Switchable Neutral

Summary: The general rule is when you have a grounded neutral at both the generator and the utility, you must use a transfer switch with enough poles to switch the neutral. If you ground the neutral in both places, you create undesirable multiple paths for ground current to flow.

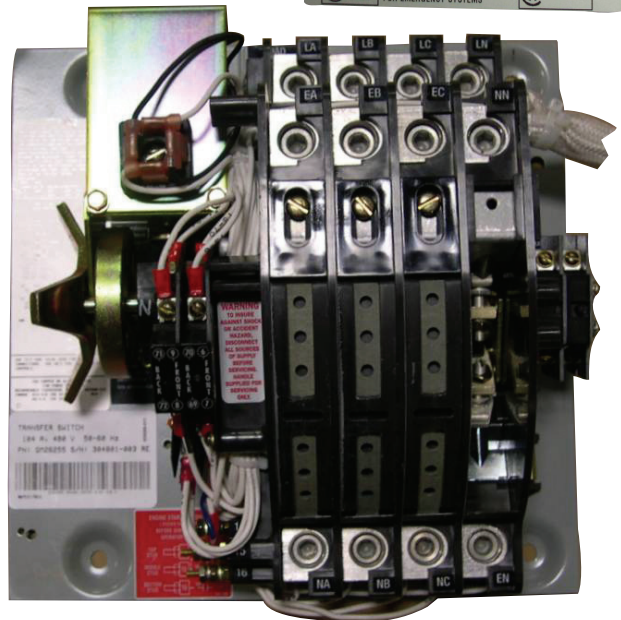
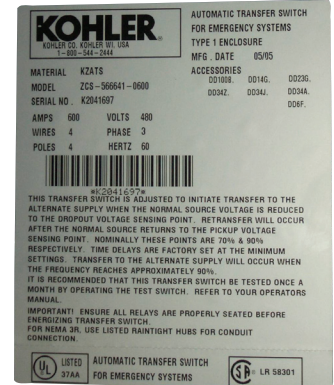

Photo above details 4-pole Transfer Switch used for switching the neutral

7 convenient Kraft Power locations, one website: www.kraftpower.com

KOHLER
POWER SYSTEMS

199 Wildwood Ave
Woburn, MA 01888
781-938-9100 T
781-933-7812 F

601 Cambridge Ave
Syracuse, NY 13208
315-455-6200 T
315-455-6300 F

241 West Parkway
Pompton Plains, NJ 07444
973-835-9800 T
973-835-5595 F

948 Blooming Glen Rd.
Perkasie, PA 18944
215-249-0200 T
215-249-1176 F

608 Cleveland Ave, SW
Canton, OH 44702
330-455-7096 T
330-455-0798 F

10615 Texland Blvd.
Charlotte, NC 28273
704-504-3033 T
704-504-5160 F

1000B Northbrook Pkwy
Suwanee, GA 30024
770-963-6288 T
770-963-9678 F

Email: info@kraftpower.com

KRAFTPOWER
The power of performance.