

## Your Reliable Guide for Power Solutions

# Vibration Isolation Used on Engine Generator Sets

Information Sheet # 10

This information sheet details the various types of vibration isolators used to protect a generator set's surroundings and the two types of vibration found in a system.

*A system designer reviews the following when considering the effects of vibration in a system:*

**Vibration types:** Two types of vibration occur within a system:

**Torsional vibration:** Engines combustion produces forces that are transmitted to the engine crankshaft and then to all the rotating masses of the engine. Correct matching of the engine and generator by the manufacturer eliminates torsional vibration.

**Linear vibration:** This type of vibration has many causes. It is difficult to isolate all the causes and vibration may change from location to location. Vibration is always in the system when a generator set is running. The designer specifies vibration isolators to reduce its transmission to its surroundings.

**Vibration to surroundings:** The location of the generator set is a major factor in transmitting vibrations to its surroundings. The unit should not be mounted directly to rock, concrete, metal, soil or other surfaces that transmit vibration over a considerable distance. Because it is preferable to install the generator set on a concrete pad, the designer should specify installation of vibration isolators between the generator set and the mounting pad. (See Information Sheet #12)

**Types of vibration isolators commonly used:** Cost and the amount of vibration to be eliminated determine which of several devices a designer could use to reduce the transmission of vibrations to surrounding surfaces. The two most common are:

**Neoprene or rubber isolators:** These are used between the set's base and pad and also to isolate generator components, such as controls. Frequently, Neoprene integral mounts are fitted by the manufacturer between the engine-generator assembly and the skid. They provide as much as 90 percent isolation efficiency, which is sufficient for most installations at or below grade level. (See Diagram One)

**Spring isolators:** These isolators provide up to 98 percent vibration isolation and are suitable for all applications. They are required when the generator set is installed above grade. When choosing a spring type, be sure the model matches the weight of the generator, to avoid overly compressing the springs. The designer should consult local codes to determine if spring isolators are required. Spring types are mounted between the generator skid and the mounting surface. (See Diagrams One and Four for details)

**Spring type with sub base tank:** When spring isolators are mounted between the concrete pad and a sub-tank, special consideration must be given to the spring isolators' selection to compensate for the variable weight of the package that will occur because of the amount of fuel in the tank. Another solution would be to specify that the spring isolators will be mounted between the generator base and the sub-base fuel tank. However, while eliminating weight considerations this solution may be less pleasing aesthetically.

**Unusual or exacting code requirements:** Two types of isolators can be used when an installation is planned in an area where state and local codes specify seismic or earthquake proof mounts, or where the installation is powering an application that is extremely sensitive to vibrations.

**Seismic prone area:** Spring isolators, sized to the weight of the generator system that are supporting and mounted between the generator skid and the concrete mounting pad can be used in seismic-prone areas. (See information sheet #14 for more details of vibration isolation in seismic areas)

**Bulk isolators:** Bulk isolators are used in the most complex and expensive of all mounting systems, but bulk isolation is also the most effective when limiting vibration is critical. Bulk isolation is achieved by mounting the generator set to a solid, massive inertia block, then surrounding that block with fiberglass, cork or other motion-absorbing material to separate it from adjacent structures. (See Diagram Three)

To fulfill our commitment to be the leading supplier in the power generation industry, the Kraft Power Corporation team ensures they are always up-to-date with the current power industry standards as well as industry trends. As a service, our **Information Sheets** are circulated on a regular basis to existing and potential power customers to maintain their awareness of changes and developments in standards, codes and technology within the power industry.

Diagram One - Neoprene Integral Vibration Isolator

1. To engine-generator
2. Skid cross member
3. Neoprene vibration isolator

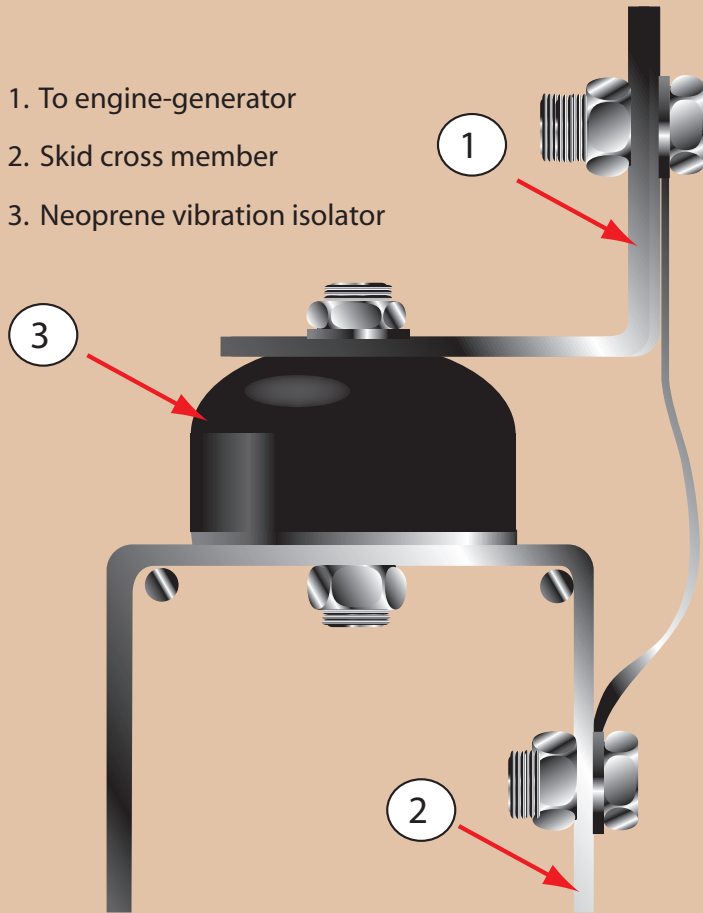

Diagram Two - Spring Vibration Isolator

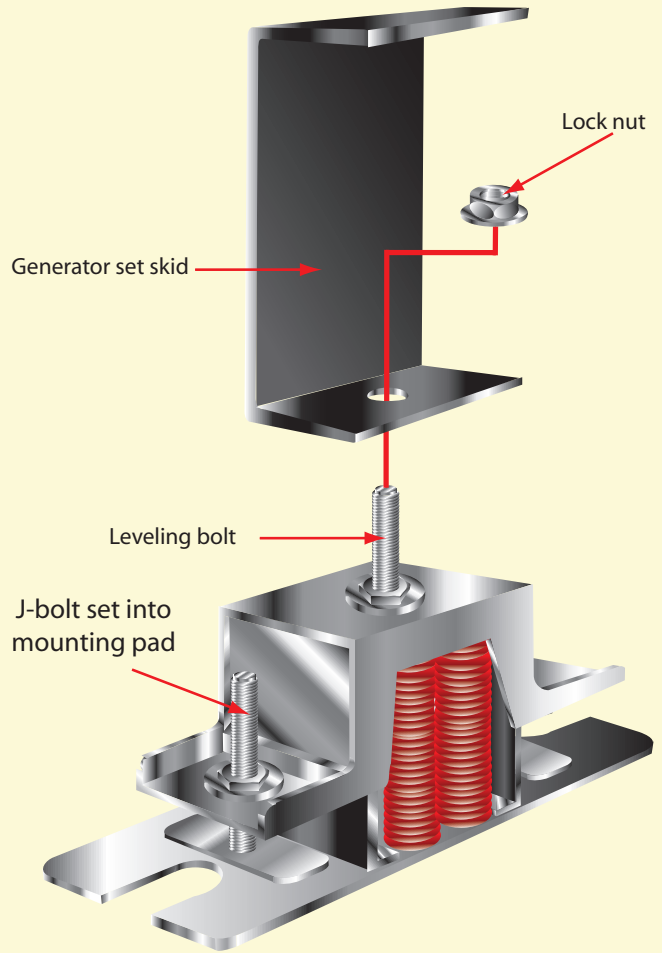

Diagram Three - Section of Bulk Vibration Isolator Mounting

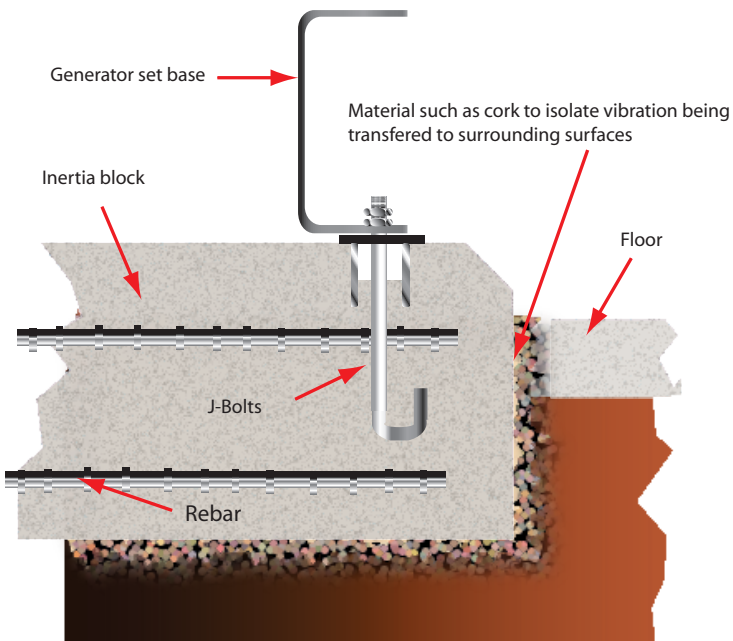
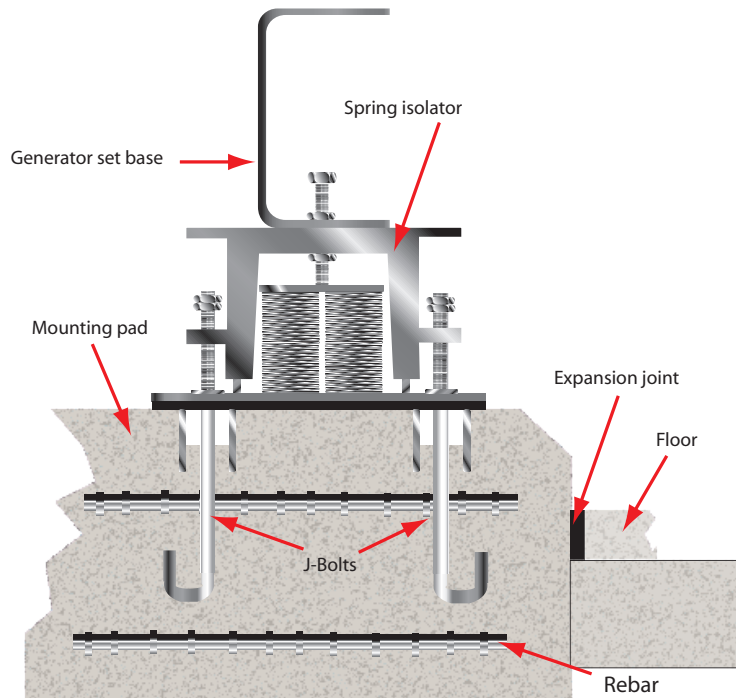

Diagram Four - Section of Spring Vibration Isolator Mounting



7 convenient Kraft Power locations, one website: [www.kraftpower.com](http://www.kraftpower.com)

**KOHLER**  
POWER SYSTEMS

199 Wildwood Ave  
Woburn, MA 01888  
781-938-9100 T  
781-933-7812 F

601 Cambridge Ave  
Syracuse, NY 13208  
315-455-6200 T  
315-455-6300 F

241 West Parkway  
Pompton Plains, NJ 07444  
973-835-9800 T  
973-835-5595 F

948 Blooming Glen Rd.  
Perkasie, PA 18944  
215-249-0200 T  
215-249-1176 F

608 Cleveland Ave, SW  
Canton, OH 44702  
330-455-7096 T  
330-455-0798 F

10615 Texland Blvd.  
Charlotte, NC 28273  
704-504-3033 T  
704-504-5160 F

1000B Northbrook Pkwy  
Suwanee, GA 30024  
770-963-6288 T  
770-963-9678 F

Email: [info@kraftpower.com](mailto:info@kraftpower.com)

**KRAFTPOWER**  
The power of performance.