

TRANSFLUID

trasmissioni industriali

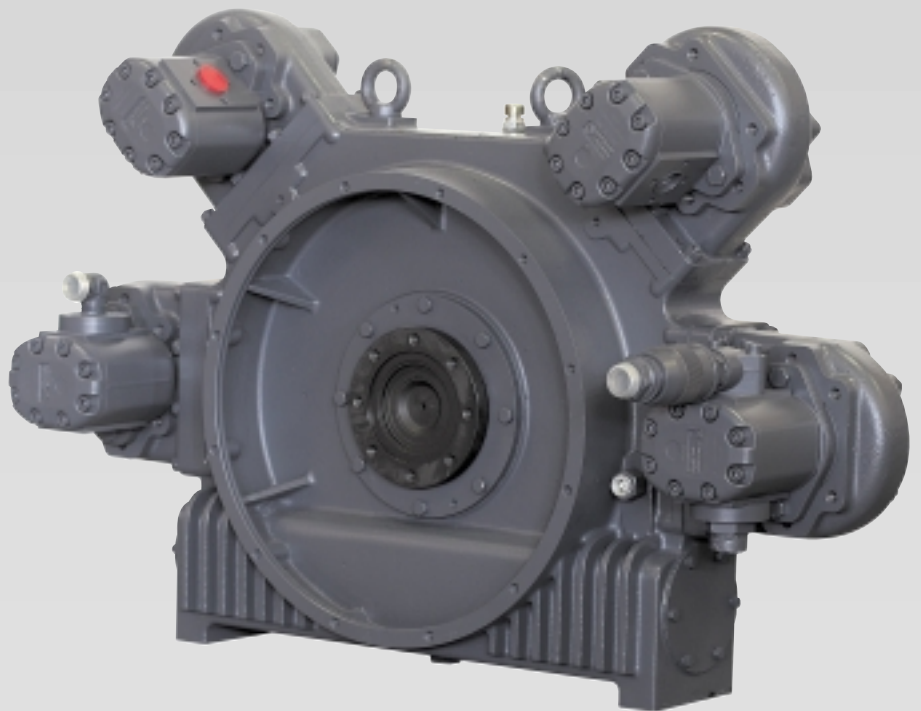

MPD
MULTI PUMP DRIVE

drive with us

MULTI PUMP DRIVE

MPD multi pump drive is an innovative module to be inserted between engine and transmission to drive a plurality of hydraulic pumps, withdrawing power directly from the engine flywheel. The MPD is directly mountable to the engine SAE housing and flywheel, featuring a built - in flexible coupling to damp torsional vibrations and compensate possible misalignment. The output side can feature a dummy flywheel and SAE housing to be connected to all kinds of marine transmissions or PTOs and particularly Transfluid HFO/HFU (oil actuated PTO), KPTO (fluid coupling) and PF - PTO (PTO with RBD rubber coupling). The unit is self-contained with its own lubrication circuit.

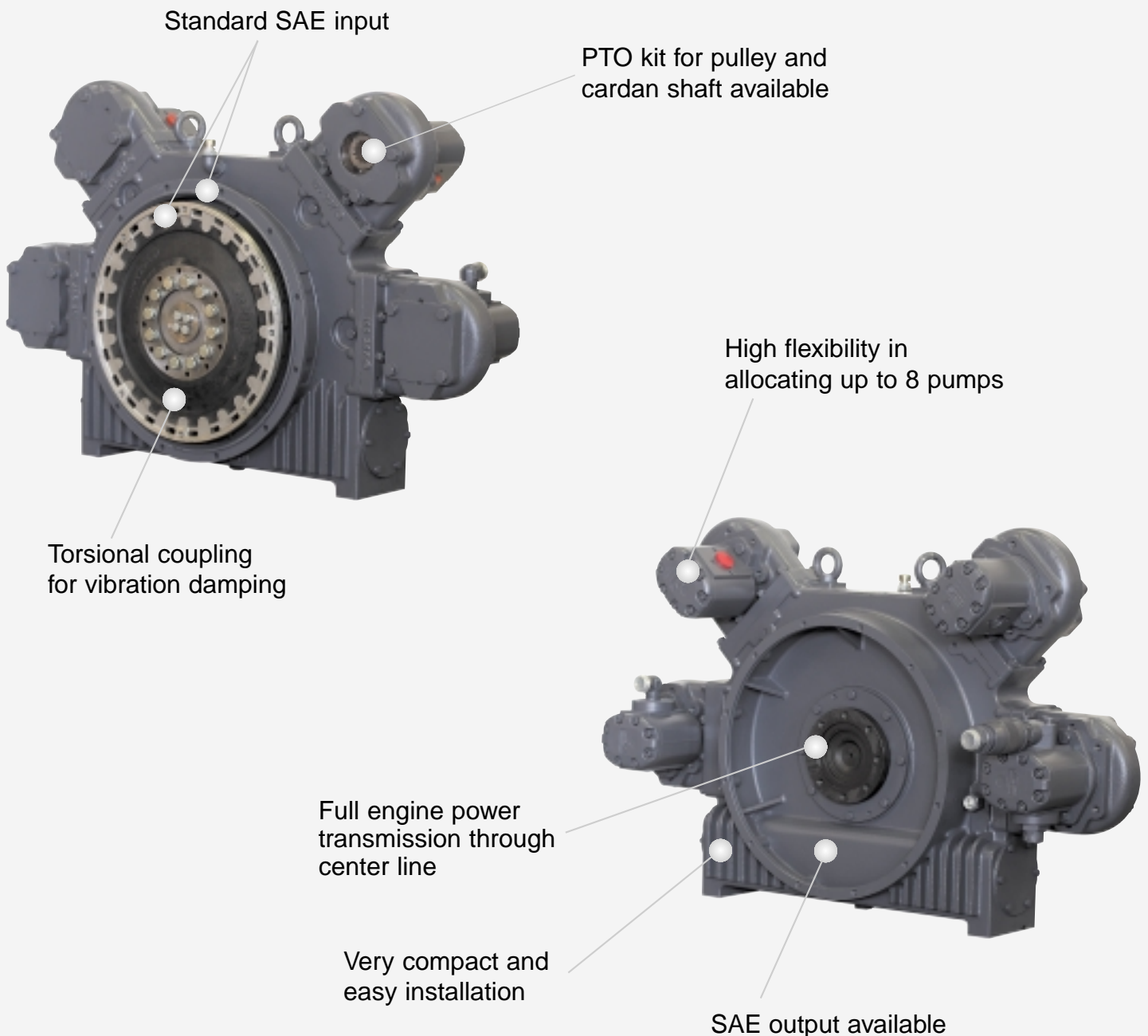

MPD 14

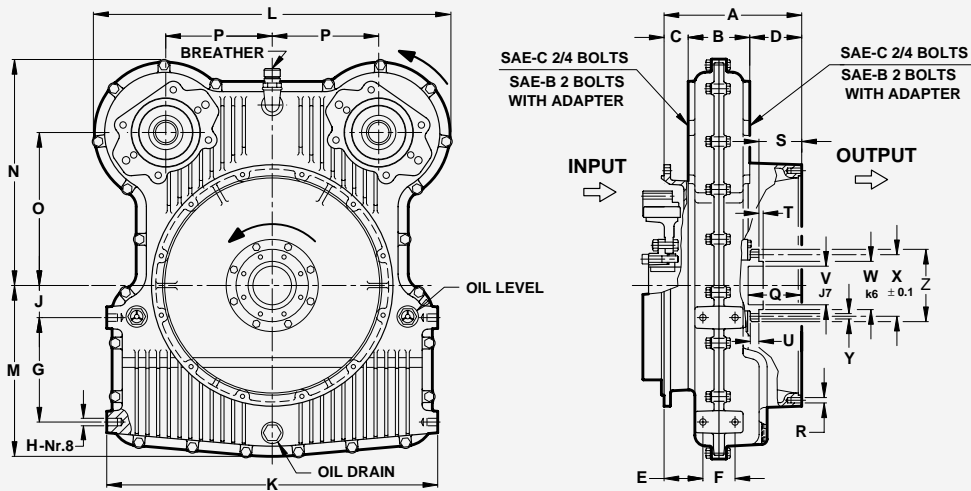

SIZE	DIMENSIONS																
	SAE INPUT	KIT SAE OUTPUT	A	B	C	D	E	F	G	H	K	J	L	M	N	O	P
14	3 - 11 $\frac{1}{2}$ " 2 - 11 $\frac{1}{2}$ " 1 - 14"	3 - 11 $\frac{1}{2}$ "	257	115	45	97	72.5	60	195	M14	672	60	672	325	422	284.508	199.215

SIZE	DIMENSIONS											TECHNICAL DATA					
	Q	R		S	T	U	V	W	X	Y		Z	Max speed rpm	Max input torque Nm	Total Head kW	Single Head kW	Ratios (n1:n2)
		Dia.	Nr.							Dia.	Nr.						
14	100	M10	12	80	8	16	72	90	115	M10	8	133	2600	2000	100	70	1.0

MPD 18-22

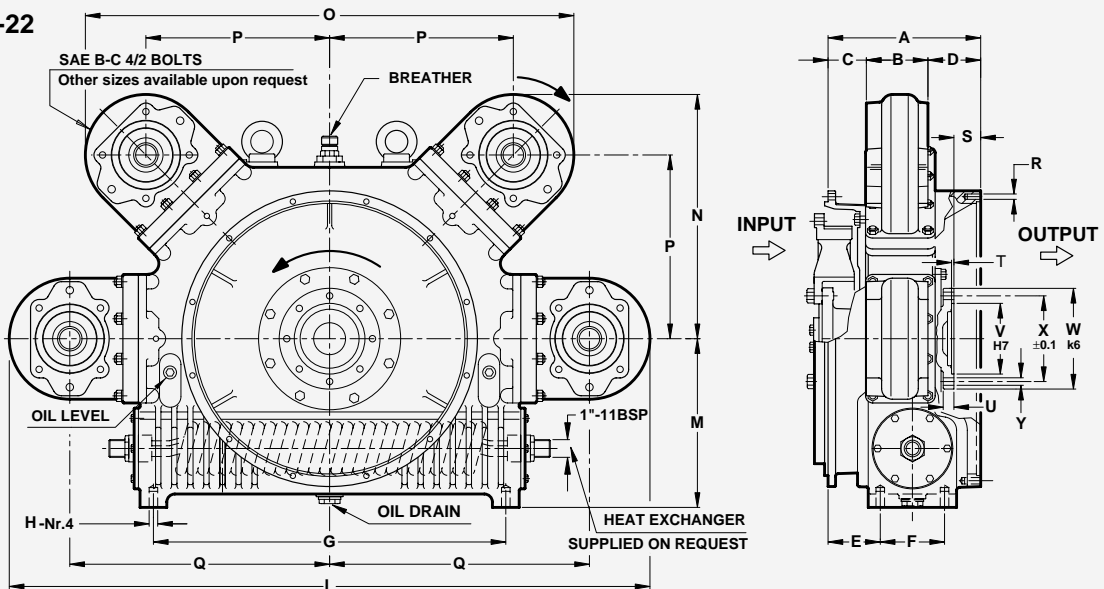

SIZE	DIMENSIONS															
	SAE INPUT	KIT SAE OUTPUT	A	B	C	D	E	F	G	H	L	M	N	O	P	Q
18	1 - 14"	1 - 14"	285	115	71.5	98.5	97.5	120	658	M16	1200	315	456	915	343.01	485.17
22	1 - 14" 0 - 18"	0 - 18"	331	115	108	108	134	130	772	M18	1330	415	505	1005	388.711	549.72

SIZE	DIMENSIONS											TECHNICAL DATA				
	R	S	T	U	V	W	X	Y		Z	Max speed rpm	Max input torque Nm	Total Head kW	Single Head kW	Ratios (n1:n2)	
								Dia.	Nr.							
18	M10	12	50	4.5	20	132	188	160	M14	8	2200	3350	200	120	1.0	
22	M12	16	45	5	25	160	225	190	M16	12	2100	6300	300	175	0.95	

Dimensions are subject to alteration without notice

MPD with HFO OIL ACTUATED PTO

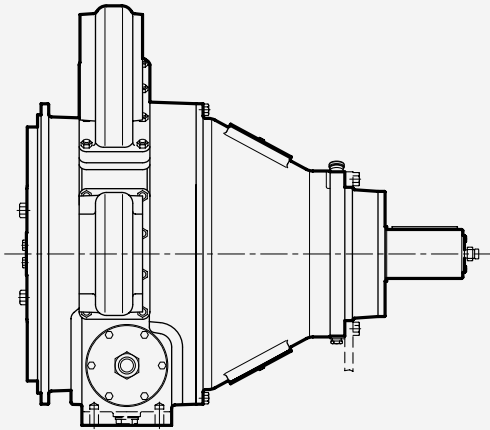

**MPD with KPTO VARIABLE FILL
FLUID COUPLING**

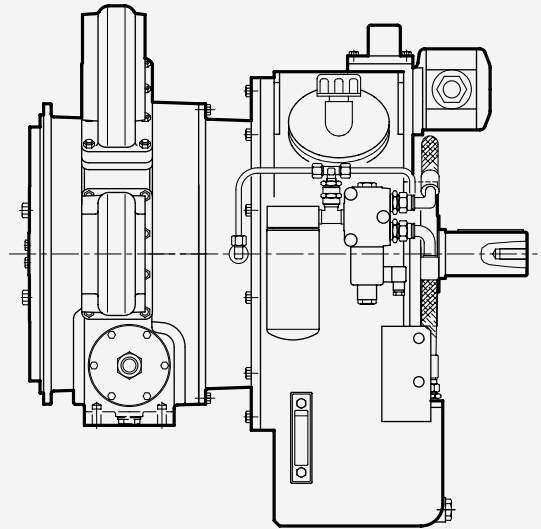

**MPD with KFBD CONSTANT FILL
FLUID COUPLING**

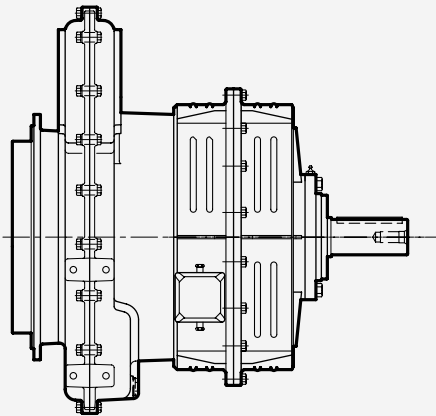

**MPD with REVERMATIC POWER
SHIFT TRANSMISSION**

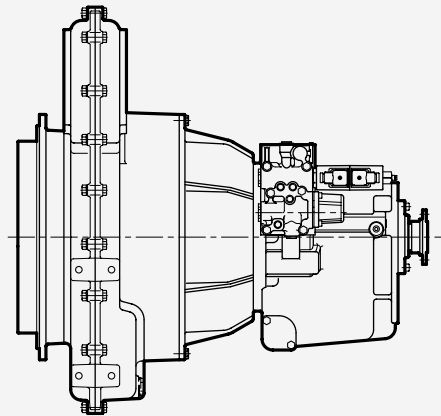

MPD with MARINE GEAR

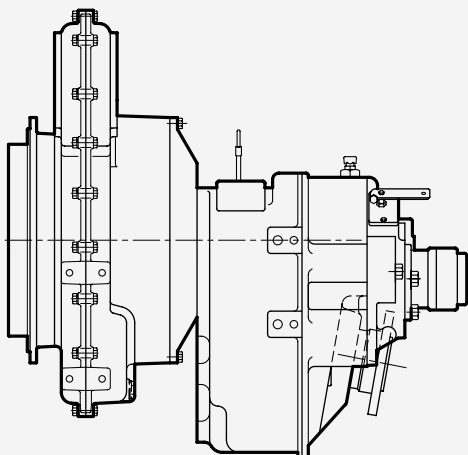

**MPD with INPUT or OUTPUT CARDAN SHAFT
(FOOT MOUNTING)**

